

HS-100S Accelerometer

AC acceleration output via 4 Core Polyolefin HFFR

Key Features

- Side entry for easy access
- Resistant to oil

Industries

Building services, Pulp and Paper, Mining, Metals, Utilities, Automotive, Water, Pharmaceutical

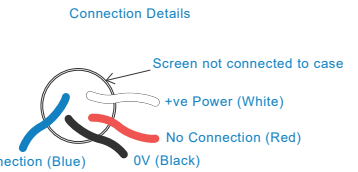
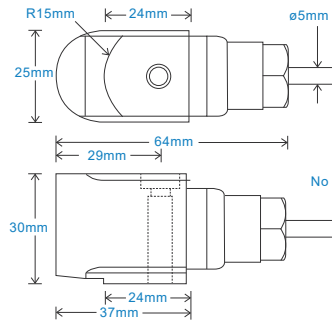
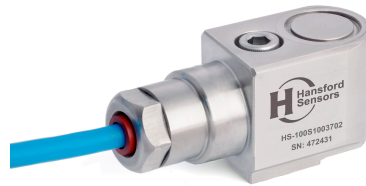

Technical Performance

Mounted Base Resonance	see 'How To Order' table (nominal)
Sensitivity	see: 'How To Order' table ±10% Nominal 80Hz at 22°C
Frequency Response	2Hz (120cpm) to 10kHz (600kcpm) ± 5% 1.5Hz (90cpm) to 12kHz (720kcpm) ± 10% 0.8Hz (48cpm) to 15kHz (900kcpm) ± 3dB
Isolation	Base isolated
Range	see: 'How To Order' table
Transverse Sensitivity	Less than 5%

Mechanical

Case Material	Stainless Steel
Sensing Element/Construction	PZT/Compression
Mounting Torque	8Nm
Mounting Bolt provided	see: 'How To Order' table x 30mm long
Weight	185gms (nominal) body only
Maximum Cable Length	1000 metres
Standard Cable Length	5 metres
Screened Cable	Polyolefin HFFR - length to be specified with order
Mounting Threads	see: 'How To Order' table

Electrical

Excitation Voltage:	18-30Volts DC
Electrical Noise	0.1mg max
Current Range	0.5mA to 8mA
Bias Voltage	10 - 12 Volts DC
Settling Time	2 seconds
Output Impedance	200 Ohms max.
Case Isolation	>10 ⁸ Ohms at 500 Volts

Environmental

Operating Temperature Range	-55 to 130°C
Sealing	IP68
Maximum Shock	5000g
EMC	EN61326-1:2013

Typical Frequency Response (at 100mV/g)

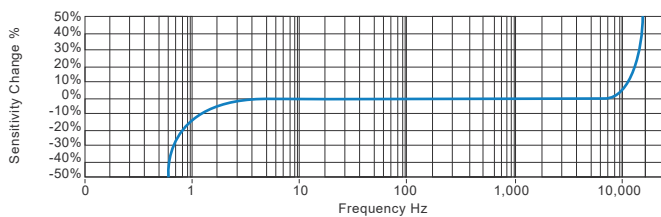

Applications

Fans, Motors, Pumps, Compressors, Centrifuges, Conveyors, Air Handlers, Gearboxes, Rolls, Dryers, Presses, Cooling, VAC, Spindles, Machine Tooling, Process Equipment

Vibration sensor should be firmly fixed to a flat surface (spot face surface may be needed to be produced and cable anchored to sensor body.)

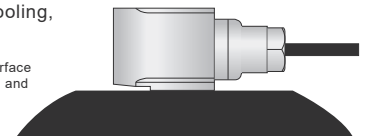

How To Order

Product Prefix HS - Hansford Sensors	Product Series 100 - Industrial Vibration Sensor	Cable Length QXX - length specified in metres												
H	S	1	0	0	S	X	X	X	X	X	X	X	X	X
Extra Options (if required) F - Filtered RT - Temperature Output PT100 S - 90° Side Exit T - Temperature Output Y - 5% tolerance on sensitivity					Sensitivity 010 - 10mV/g 030 - 30mV/g 050 - 50mV/g 100 - 100mV/g 250 - 250mV/g 500 - 500mV/g	Range ±800g ±250g ±160g ±80g ±32g ±16g	Resonant Frequency 27kHz (1,620kcpm) 25kHz (1,500kcpm) 23kHz (1,380kcpm) 21kHz (1,260kcpm) 19kHz (1,140kcpm) 17kHz (1,020kcpm)	Cable/Connector 37 - 4 Core Polyolefin HFFR				Mounting Threads 02 - ¼-28" UNF Male 06 - M6 x 1mm Male 08 - M8 x 1.25mm Male		



T: 150 210 98804

www.hansfordsensors.com.cn

汉施弗德传感器（上海）有限公司

