

HS-100IS Intrinsically Safe Accelerometer

AC acceleration output via Braided Cable

Key Features

- Intrinsically Safe with European, USA, South African, Indian and Australian approvals
- Side entry for easy access

Industries

Building services, Pulp and Paper, Mining, Metals, Utilities, Automotive, Water, Pharmaceutical

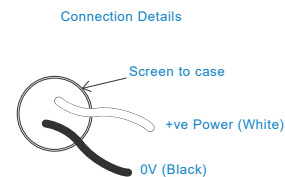
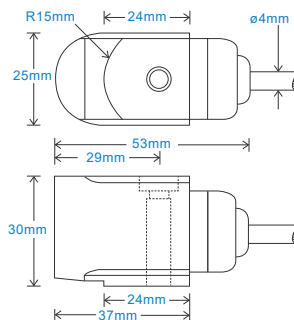

Technical Performance

Mounted Base Resonance	see 'How To Order' table (nominal)
Sensitivity	see: 'How To Order' table $\pm 10\%$ Nominal 80Hz at 22°C
Frequency Response	2Hz (120cpm) to 10kHz (600kcpm) $\pm 5\%$ 1.5Hz (90cpm) to 12kHz (720kcpm) $\pm 10\%$ 0.8Hz (48cpm) to 15kHz (900kcpm) $\pm 3\text{dB}$
Isolation	Base isolated
Range	see: 'How To Order' table
Transverse Sensitivity	Less than 5%

Mechanical

Case Material	Stainless Steel
Sensing Element/Construction	PZT/Compression
Mounting Torque	8Nm
Mounting Bolt Provided	see: 'How To Order' table x 30mm long
Weight	185gms (nominal) body only
Maximum Cable Length	1000 metres
Standard Cable Length	5 metres
Screened Cable	Braided - length to be specified with order
Mounting Threads	see: 'How To Order' table

Electrical

Excitation Voltage:	18-30Volts DC
Electrical Noise	0.1mg max
Current Range	0.5mA to 8mA
Bias Voltage	10 - 12 Volts DC
Settling Time	2 seconds
Output Impedance	200 Ohms max.
Case Isolation	$>10^8$ Ohms at 500 Volts

Environmental

Operating Temperature Range	see: attached certification details
Sealing	IP65
Maximum Shock	5000g
EMC	EN61326-1:2013

Typical Frequency Response (at 100mV/g)

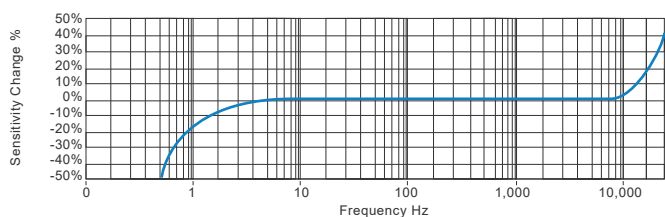

Applications

Fans, Motors, Pumps, Compressors, Centrifuges, Conveyors, Air Handlers, Gearboxes, Rolls, Dryers, Presses, Cooling, VAC, Spindles, Machine Tooling, Process Equipment

Vibration sensor should be firmly fixed to a flat surface (spot face surface may be needed to be produced and cable anchored to sensor body.)

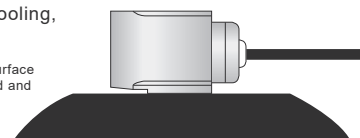

Certifications



This product is certified in accordance with
UL 913, 8th Ed. Rev. December 6, 2013
CAN/CSA C22.2 No. 157-92 (R2012) +Upd1 +Upd2



T: 150 210 98804
www.hansfordsensors.com.cn
 汉施弗德传感器（上海）有限公司



HS-100IS Intrinsically Safe Accelerometer

AC acceleration output via Braided Cable

Intrinsically Safe Requirements

Maximum Cable Length	See www.hansfordsensors.com.cn see attached system drawing	Certified Temperature Range	Ex ia IIC T6 Ga (-55°C ≤ Ta ≤ +60°C) (Gas) Ex ia IIIC T80°C IP65 Da (-55°C ≤ Ta ≤ +60°C) (Dust) Ex ia IIC T4 Ga (-55°C ≤ Ta ≤ +110°C) (Gas)* Ex ia IIIC T130°C IP65 Da (-55°C ≤ Ta ≤ +110°C) (Dust)* Ex ia I Ma (-55°C ≤ Ta ≤ +110°C) (Mining) *On request - consult Sales Office
Certificate details: Group I	IECEX BAS07.0037X Baseefa07ATEX0149X ⓈI M1 Ex ia I Ma (-55°C ≤ Ta ≤ +110°C)	Australia Approval Group I	IECEX ITA 11.0013X Ex ia I Ma (-55°C ≤ Ta ≤ +110°C)
Certificate details: Group II (ignition temperature 130°C)	IECEX BAS07.0035X Baseefa07ATEX0144X ⓈII 1GD Ex ia IIC T4 Ga Ex ia IIIC T130°C IP65 Da (-55°C ≤ Ta ≤ +110°C)	US/Canada Approvals	Certificate No. USTC/15/FAI/01350 Class I, II, III, Division 1, 2, Groups A - G, T4, -55°C to +110°C, IP65 Class I, Zone 0, AEx, ia, IIC, T4, Ga, -55°C to +110°C Zone 20, AEx, ia, IIIC, T130°C, IP65, Da, -55°C to +110°C
Certificate details: Group II (ignition temperature 80°C)	IECEX BAS07.0035X Baseefa07ATEX0144X ⓈII 1GD Ex ia IIC T6 Ga Ex ia IIIC T80°C IP65 Da (-55°C ≤ Ta ≤ +60°C)	Class I, II, III, Division 1, 2, Groups A - G, T6, -55°C to +60°C Class I, Zone 0, AEx, ia, IIC, T6, Ga, -55°C to +60°C Zone 20, AEx, ia, IIIC, T80°C, IP65, DA, -55°C to +60°C	South African Approval
Accelerometer System Certificate	Baseefa07Y0145 Ex ia IIC T6 (-55°C ≤ Ta ≤ +60°C) Ex ia IIC T4 (-55°C ≤ Ta ≤ +110°C) On request - consult Sales Office	System Connections	Certificate No. MASC S/16-0231X Group II (As Baseefa/ATEX) MASC M/16-0230X Group I (As Baseefa/ATEX)
Terminal Parameters	Ui = 28V, Ii = 93mA, Pi = 0.65W Ci = 83nf Li/Ri = 15.4µH/Ohm	Barrier	1 x Pepperl + Fuchs Galvanic Isolator KFD2-VR4-Ex1.26 (BAS02ATEX7206) see attached system drawings 1 x MTL Zener Barrier MTL7728+ (BAS01ATEX7217) or Pepperl + Fuchs Zener Barrier Z728 (BAS01ATEX7005) or any other barrier that conforms to system drawings on website
500V Isolation	Units Will Pass A 500V Isolation Test		

Notes: Special conditions of safe use for Group I & II. The free end of the cable on the integral cable version of the apparatus must be terminated in an appropriate dust-proof enclosure.

Intrinsically Safe Requirements for IC3 Variations

HS-100IC3 Variation is certified as Category 3 equipment. These sensors are only certified for use within Zones 2.	Certified Temperature Range	Ex ic IIC T4 Gc (-55°C ≤ Ta ≤ +110°C)
	Terminal Parameters	Ui = 25.2V, Ii = 146mA, Pi = 0.92W Ci = 83nf Li 6µH
Certificate Details: Group II (ignition temperature 130°C)	IECEX BAS17.0054X Baseefa7ATEX0069X ⓈII 3G Ex ic IIC T4 Gc (-55°C ≤ Ta ≤ +110°C)	500V Isolation
	Special Conditions of Use:	Units will pass a 500V Isolation Test The Ci and Li parameters listed on the equipment certificate must be taken into account when connecting this equipment.

How To Order

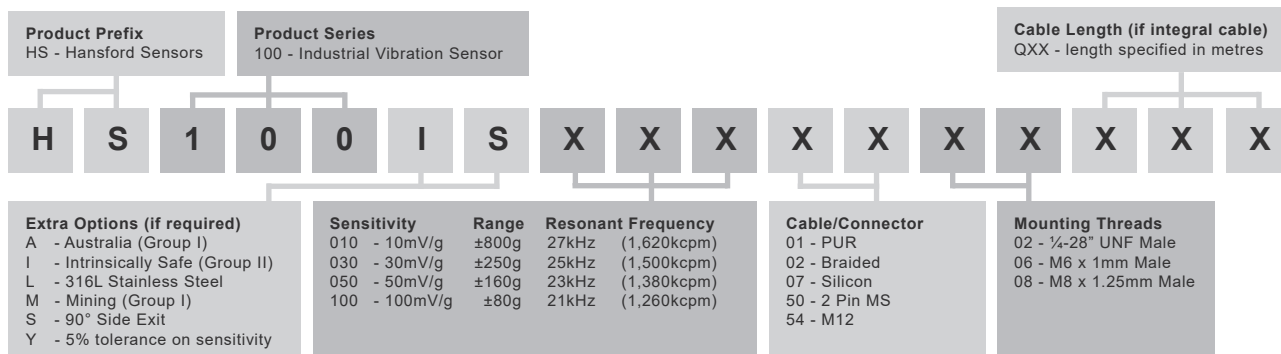

T: 150 210 98804
www.hansfordsensors.com.cn
 汉施弗德传感器（上海）有限公司



Non-hazardous area apparatus which is unspecified except that it must not be supplied from nor contain under normal or abnormal conditions, a source of potential with respect to earth in excess of 250 volts rms or 250 volts dc. under normal conditions the potential at the connections to the zener barrier must not exceed 40 volts dc.

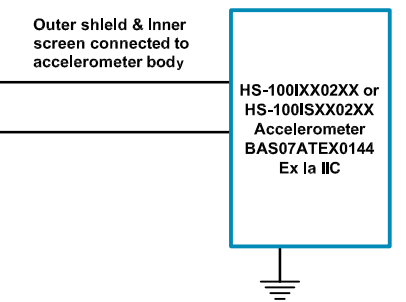
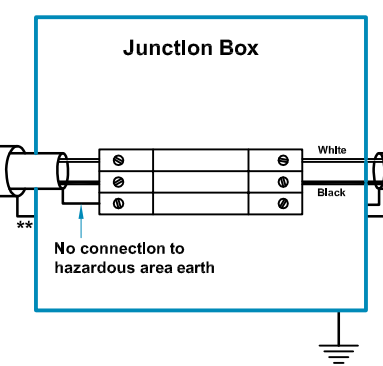
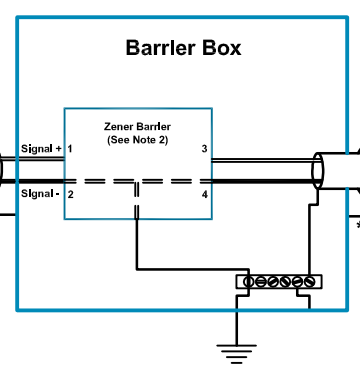

**Outer shield only connected to chassis via Ex approved cable gland

*Outer shield & Inner screen connected to chassis via Ex approved cable gland

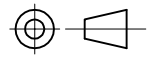

Table 1: Cable Parameters For Additional Cable Lengths		
Accelerometer With Integral Cable Length ≤ 10m		
Group	Capacitance μF	L/R Ratio μH/Ω
IIC	0.073	56
IIB	0.239	168
IIA	0.654	448
Accelerometer With Integral Cable Length ≤ 50m		
Group	Capacitance μF	L/R Ratio μH/Ω
IIC	0.038	56
IIB	0.204	168
IIA	0.619	448
Accelerometer With Integral Cable Length ≤ 92m		
Group	Capacitance μF	L/R Ratio μH/Ω
IIC	0.000	56
IIB	0.166	168
IIA	0.581	448

Hansford Sensors Ltd

HS-100I or HS-100IS
Accelerometer System
Baseefa07Y0145/1
Ex ia IIC T4 (-55°C ≤ Ta ≤ +110°C) or
Ex ia IIC T6 (-55°C ≤ Ta ≤ +60°C)

Notes:

- The capacitance and inductance, to resistance ratio (L/R) of hazardous area cable, must not exceed the values shown in Table 1.
- Any single zener diode safety barrier certified by an approved body to [Ex ia] IIC having the following output parameters: U_o = 28V dc, I_o = 93mA dc, P_o = 0.65W. e.g. MTL728 to BAS01ATEX7217 or Pepperl + Fuchs Z728 to BAS01ATEX7005.
- The installer is to perform a risk assessment in accordance with clause 10 of EN 60079-25 and install lightning protection arrestors as deemed necessary.

Rev No	DRF No	Date Drg	Drg By	Appd By	Material: N/A	 Hansford Sensors Ltd Excellence in Vibration Monitoring Hansford Sensors Ltd Artisan, Hillbottom Rd Sands Industrial Estate High Wycombe Bucks HP12 4HJ	 Do Not Scale All Dimensions In mm Unless Otherwise Stated If In Doubt - Ask!	Description: System Connections For HS-100I & HS-100IS Group II Accelerometers With Armoured Cable F.U.W. Zener Barrier Drawing No: M06-003-B	
A	Release	15/06/07	MJS	CMH	Tolerances Unless Stated 0 or 0.0 ±0.5 0.00 ±0.15 Angle ±5°			Scale: NTS Sheet: 2 of 2	Form Number: QF024 Issue 1
B	DFR0164	13/01/11	MJS	CMH		 Finish All Over Threads g6 H6			