

HS-420 Accelerometer

4-20mA velocity output via Flame Retardant Cable for use with Terminal Head

Key Features

- For use with Terminal Head
- Customizable features

Industries

Building services, Pulp and Paper, Mining, Metals, Utilities, Automotive, Water, Pharmaceutical

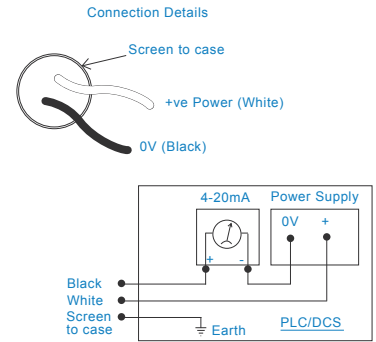
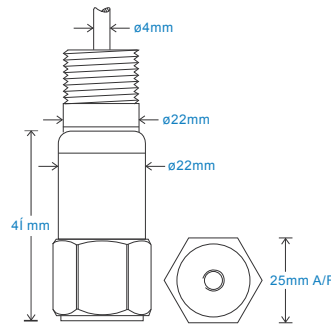

Technical Performance

Mounted Base Resonance	5kHz min
Velocity Ranges	see: 'How To Order' table $\pm 10\%$ Nominal 80Hz at 22°C
Frequency Response	10Hz (600cpm) to 1kHz (60kcpm) $\pm 5\%$ - ISO10816
Isolation	Base isolated
Range	50g peak
Transverse Sensitivity	Less than 5%

Mechanical

Case Material	Stainless Steel
Sensing Element/Construction	PZT/Compression
Mounting Torque	8Nm
Weight	100gms (nominal) body only
External Cable Length	site cable up to 1000 metres
Integral Cable Length	up to 300 mm
Cable Connections	Screw Terminals
Mounting Threads	see: 'How To Order' table

Electrical

Current Output	4-20mA DC proportional to Velocity Range
Supply Voltage	15-30 Volts DC (for 4-20mA)
Settling Time	2 seconds
Output Impedance	Loop Resistance 600 Ohms max. at 24 Volts
Case Isolation	$>10^8$ Ohms at 500 Volts

Environmental

Operating Temperature Range	-25 to 90°C
Sealing	IP65
Maximum Shock	5000g
EMC	EN61326-1:2013

Typical Frequency Response

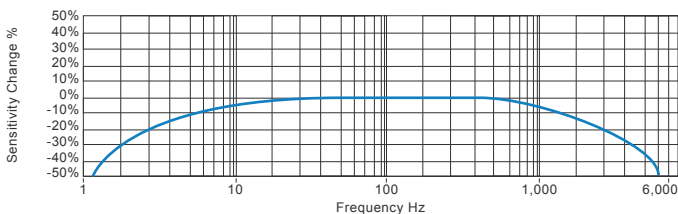

Applications

Fans, Motors, Pumps, Compressors, Centrifuges, Conveyors, Air Handlers, Gearboxes, Rolls, Dryers, Presses, Cooling, VAC, Spindles, Machine Tooling, Process Equipment

Vibration sensor should be firmly fixed to a flat surface (spot face surface may be needed to be produced and cable anchored to sensor body.)

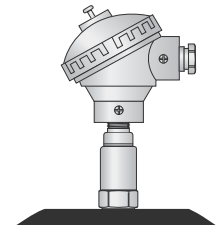

How To Order

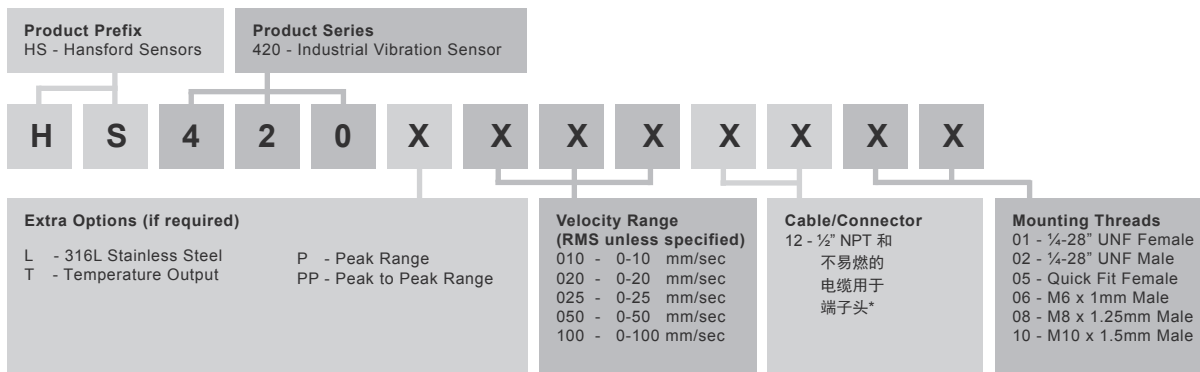

*HS-AA042 or HS-AA052 Terminal Head to be purchased separately



T: 150 210 98804
www.hansfordsensors.com.cn
汉施弗德传感器（上海）有限公司

