

HS-420RT Accelerometer

4-20mA velocity and PT100 temperature output via PUR Cable

Key Features

- Waterproof
- Resistant to oil
- PT100 temperature output

Industries

Building services, Pulp and Paper, Mining, Metals, Utilities, Automotive, Water, Pharmaceutical

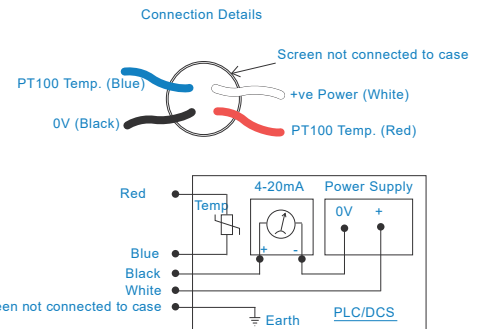
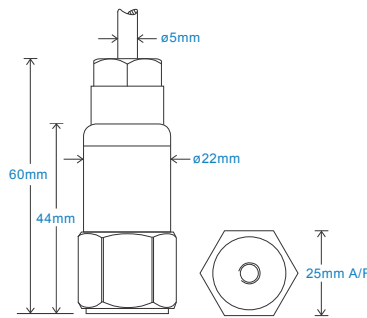

Technical Performance

Mounted Base Resonance	5kHz min
Velocity Ranges	see: 'How To Order' table $\pm 10\%$ Nominal 80Hz at 22°C
Frequency Response	10Hz (600cpm) to 1kHz (60kcpm) $\pm 5\%$ - ISO10816
Isolation	Base isolated
Range	50g peak
Temperature Output	PT100 (100 Ohms)
Transverse Sensitivity	Less than 5%

Mechanical

Case Material	Stainless Steel
Sensing Element/Construction	PZT/Compression
Mounting Torque	8Nm
Weight	100gms (nominal) body only
Maximum Cable Length	1000 metres
Standard Cable Length	5 metres
Screened Cable	PUR - length to be specified with order
Mounting Threads	see: 'How To Order' table
Submersible Depth	100 metres max (10 bar)

Electrical

Current Output	4-20mA DC proportional to Velocity Range
Supply Voltage	15-30 Volts DC (for 4-20mA)
Settling Time	2 seconds
Output Impedance	Loop Resistance 600 Ohms max. at 24 Volts
Case Isolation	$>10^8$ Ohms at 500 Volts

Environmental

Operating Temperature Range	-25 to 90°C
Sealing	IP68
Maximum Shock	5000g
EMC	EN61326-1:2013

Typical Frequency Response

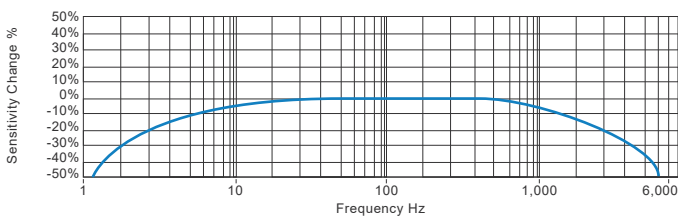

Applications

Fans, Motors, Pumps, Compressors, Centrifuges, Conveyors, Air Handlers, Gearboxes, Rolls, Dryers, Presses, Cooling, VAC, Spindles, Machine Tooling, Process Equipment

Vibration sensor should be firmly fixed to a flat surface (spot face surface may be needed to be produced and cable anchored to sensor body.)

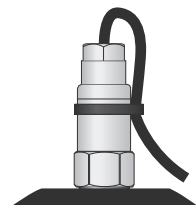

How To Order

Product Prefix HS - Hansford Sensors	Product Series 420 - Industrial Vibration Sensor	Cable Length (if integral cable) QXX - length specified in metres															
H	S	4	2	0	R	T	X	X	X	X	X	X	X	X	X		
Extra Options (if required) F - Filtered I - Intrinsically Safe L - 316L Stainless Steel RT - Temperature Output PT100 S - 90° Side Exit						Velocity Range (RMS unless specified) 010 - 0-10 mm/sec 020 - 0-20 mm/sec 025 - 0-25 mm/sec 050 - 0-50 mm/sec 100 - 0-100 mm/sec			Cable/Connector 01 - PUR 54 - M12			Mounting Threads 01 - 1/4-28" UNF Female 02 - 1/2-28" UNF Male 05 - Quick Fit Female 06 - M6 x 1mm Male 08 - M8 x 1.25mm Male 10 - M10 x 1.5mm Male					
P - Peak Range PP - Peak to Peak Range																	



T: 150 210 98804
www.hansfordsensors.com.cn
汉施弗德传感器（上海）有限公司

