

HS-421 Accelerometer

4-20mA velocity and AC acceleration output via Braided Cable

Key Features

- Unique output
- For use with PLC/DCS systems and data collectors
- Customisable features

Industries

Building services, Pulp and Paper, Mining, Metals, Utilities, Automotive, Water, Pharmaceutical

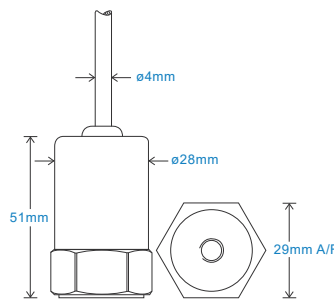

Connection Details

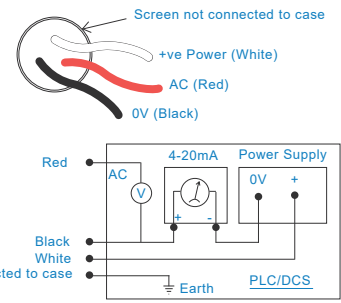

Technical Performance

Mounted Base Resonance	5kHz min
Velocity Ranges	see: 'How To Order' table $\pm 10\%$ Nominal 80Hz at 22°C
Frequency Response: 4-20mA	10Hz (600cpm) to 1kHz (60kcpm) $\pm 5\%$ - ISO10816
Frequency Response: AC	2Hz (120cpm) to 10kHz (600kcpm) $\pm 5\%$ - ISO10816
Isolation	Base isolated
Range	see: 'How To Order' table
Transverse Sensitivity	Less than 5%

Mechanical

Case Material	Stainless Steel
Sensing Element/Construction	PZT/Compression
Mounting Torque	8Nm
Weight	150gms (nominal) body only
Maximum Cable Length	1000 metres
Standard Cable Length	5 metres
Screened Cable	Braided - length to be specified with order
Mounting Threads	see: 'How To Order' table

Electrical

Outputs	4-20mA DC current proportional to Range and AC acceleration
Bias Voltage	3 Volts DC (nominal)
Supply Voltage	15-30 Volts DC (for 4-20mA)
Settling Time	2 seconds
Output Impedance	Loop Resistance 600 Ohms max. at 24 Volts
Case Isolation	$>10^8$ Ohms at 500 Volts

Environmental

Operating Temperature Range	-25 to 120°C
Sealing	IP65
Maximum Shock	5000g
EMC	EN61326-1:2013

Typical Frequency Response (4-20mA signal)

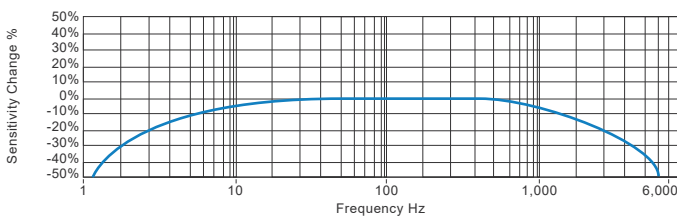

Applications

Fans, Motors, Pumps, Compressors, Centrifuges, Conveyors, Air Handlers, Gearboxes, Rolls, Dryers, Presses, Cooling, VAC, Spindles, Machine Tooling, Process Equipment

Vibration sensor should be firmly fixed to a flat surface (spot face surface may be needed to be produced and cable anchored to sensor body.)

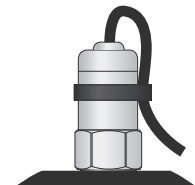

How To Order

Product Prefix HS - Hansford Sensors	Product Series 421 - Industrial Vibration Sensor	Cable Length (if integral cable) QXX - length specified in metres												
H	S	4	2	1	X	X	X	X	X	X	X	X	X	X
Extra Options (if required) F - Filtered L - 316L Stainless Steel RT - Temperature Output PT100 S - 90° Side Exit T - Temperature Output					Velocity Range (RMS unless specified) 010 - 0-10 mm/sec 020 - 0-20 mm/sec 025 - 0-25 mm/sec 050 - 0-50 mm/sec 100 - 0-100 mm/sec			Sensitivity Range 100mV/g $\pm 30g$ 100mV/g $\pm 30g$ 100mV/g $\pm 30g$ 50mV/g $\pm 60g$ 50mV/g $\pm 60g$		Cable/Connector 01 - PUR 03 - Braided 07 - Silicon 15 - Flame Retardant 52 - 3 Pin MS 54 - M12			Mounting Threads 01 - 1/4-28" UNF Female 02 - 1/4-28" UNF Male 05 - Quick Fit Female 06 - M6 x 1mm Male 08 - M8 x 1.25mm Male 10 - M10 x 1.5mm Male	



T: 150 210 98804
www.hansfordsensors.com.cn
汉施弗德传感器（上海）有限公司

