

# HS-422RT Accelerometer

4-20mA acceleration and PT100 temperature output via M12 Connector

## Key Features

- 4-20mA acceleration output
- For use with PLC/DCS systems
- PT100 temperature output

## Industries

Building services, Pulp and Paper, Mining, Metals, Utilities, Automotive, Water, Pharmaceutical

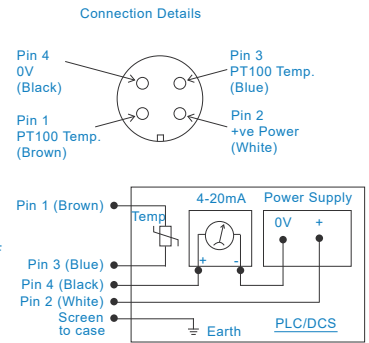
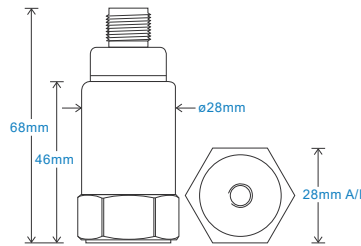

## Technical Performance

Mounted Base Resonance	10kHz min
Acceleration Ranges	see: 'How To Order' table $\pm 10\%$ Nominal 80Hz at 22°C
Frequency Response	10Hz (600cpm) to 5kHz (300kcpm) $\pm 5\%$ - ISO10816
Isolation	Base isolated
Range	see: 'How To Order' table
Temperature Output	PT100 (100 Ohms)
Transverse Sensitivity	Less than 5%

## Mechanical

Case Material	Stainless Steel
Sensing Element/Construction	PZT/Compression
Mounting Torque	8Nm
Weight	150gms (nominal)
Screened Cable Assembly	HS-AC010 - straight HS-AC011 - right angle
Mounting Threads	see: 'How To Order' table

## Electrical

Current Output	4-20mA DC proportional to acceleration
Supply Voltage	15-30 Volts DC (for 4-20mA)
Settling Time	2 seconds
Output Impedance	Loop Resistance 600 Ohms max. at 24 Volts
Case Isolation	$>10^8$ Ohms at 500 Volts

## Environmental

Operating Temperature Range	-25 to 90°C
Sealing	IP67
Maximum Shock	5000g
EMC	EN61326-1:2013

## Typical Frequency Response

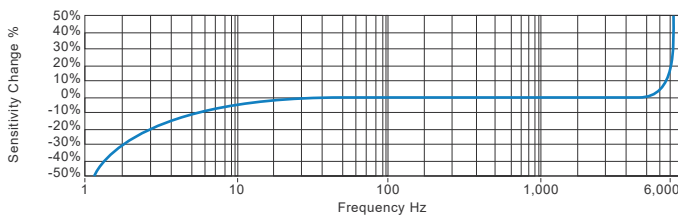

## Applications

Fans, Motors, Pumps, Compressors, Centrifuges, Conveyors, Air Handlers, Gearboxes, Rolls, Dryers, Presses, Cooling, VAC, Spindles, Machine Tooling, Process Equipment

Vibration sensor should be firmly fixed to a flat surface (spot face surface may be needed to be produced and cable anchored to sensor body.)

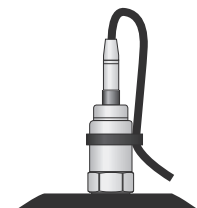

## How To Order

<b>Product Prefix</b> HS - Hansford Sensors	<b>Product Series</b> 422 - Industrial Vibration Sensor	<b>Cable Length (if integral cable)</b> QXX - length specified in metres													
H	S	4	2	2	R	T	X	X	X	X	X	X	X	X	X
<b>Extra Options (if required)</b> F - Filtered L - 316L Stainless Steel RT - Temperature Output PT100 S - 90° Side Exit							<b>Acceleration Range (RMS unless specified)</b> 001 - 0-1g 002 - 0-2g 005 - 0-5g 010 - 0-10g 100 - 0-100g			<b>Cable/Connector</b> 01 - PUR 54 - M12			<b>Mounting Threads</b> 01 - 1/4-28" UNF Female 02 - 1/4-28" UNF Male 05 - Quick Fit Female 06 - M6 x 1mm Male 08 - M8 x 1.25mm Male 10 - M10 x 1.5mm Male		



T: 150 210 98804  
www.hansfordsensors.com.cn  
汉施弗德传感器（上海）有限公司

